

1.7 PROFILO 7

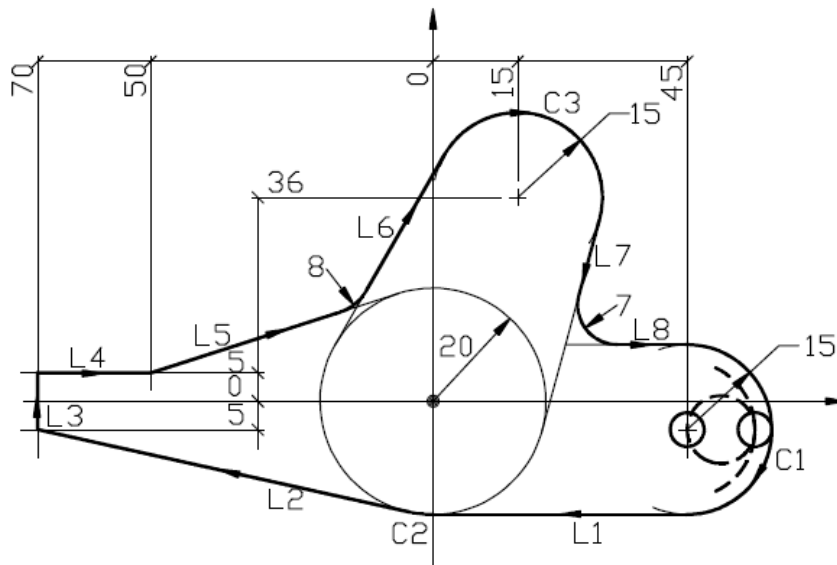

N1	[PROFILO 7	
N2	O1	[origine 1 nel piano
N3	T1 M6	[richiama utensile 1
N4	F400S1100M3	[dati tecnologici
N5	G49I4	[fresa raggio 4
N6	X45Y-5Z2R	[posizionamento rapido
N7	Z-10	[discesa
N8	G42K2	[attacco circolare a destra di C1
N9	G20X45Y-5I-15	[C1
N10	G11X0Y0I-20	[L1
N11	G20	[C2
N12	G11X-70Y-5	[L2
N13	G11Y5	[L3
N14	G13J0	[L4
N15	G10X-50Y5	
N16	G11X0Y0I-20	[L5
N17	G21I8	[R8
N18	G10X0Y0I-20	
N19	G11X15Y36I-15	[L6
N20	G20	[C3
N21	G11X0Y0I-20	[L7
N22	G21I7	[R7
N23	G13X45Y-5I-15J0	[L8
N24	G20	[C1
N25	G40X45Y-5K2	[uscita circolare sul punto
N26	Z2R	[risalita
N27	M30	[fine programma